

230 / 410



Important Safeguards

This appliance is not intended for use by children or infirm persons without supervision. Young children should be supervised to ensure that they do not play with the appliance.

Warning: To guard against injury, basic safety precautions should be observed, including the following:

1. Read and follow all safety instructions before using this appliance.

2. Danger: To avoid possible electric shocks, special care should be taken since water is employed in the use of terrarium equipment. For each of the following situations do not attempt repairs yourself. Return the appliance to an authorised service facility for service or discard the appliance.

a) If any appliance falls into water, do not reach for it, unplug it and then retrieve it. If the electrical components of the appliance get wet, unplug the appliance immediately (non immersible equipment only).

b) If the terrarium shows any sign of abnormal water leakage, immediately unplug it from the power source.

c) Carefully examine all appliances after installation. It should not be plugged in when there is water on parts which are not intended to be wet.

d) Do not operate any aquarium electrical appliance if it has a damaged cord or plug, or if it is malfunctioning, or dropped or damaged in any manner.

e) The external flexible cable or cord of this water pump cannot be replaced. If the cord is damaged the pump should be scrapped.

A "drip loop" (See the diagram) should be arranged by the user for each cord connecting a terrarium component to a receptacle. The drip loop is the part of the cord below the level of the receptacle or the connector if an extension cord is used. It is used to prevent water traveling along the cord and coming in contact with the receptacle.

If the plug or receptacle does get wet, do not unplug the appliance. Disconnect the fuse or circuit breaker that supplies the power to the appliance, then unplug and examine for presence of water in the receptacle.

3. Close supervision is necessary when the appliance is used by or near children.

4. Always unplug the water pump from the electrical outlet, when not in use, before putting on or taking off parts, before any type of maintenance, or cleaning. Never yank the cord to pull it from the outlet. Grasp the plug and unplug to disconnect.

5. Do not use the water pump for reasons other than the intended use. The use of attachments that are not recommended or sold by the filter manufacturer may cause the product to be unsafe. This is not recommended.

6. Do not install or store the water pump where it will be exposed to weather or temperatures below freezing.

7. Make sure any component mounted on a terrarium is securely installed before operating it.

8. Read and observe all the important notices on the water pump.

9. Ensure input voltage is the same voltage as your local power supply.

10. A G.F.C.I (Ground Fault Circuit Interrupter) & surge protector is recommended for all electrical appliances.

11. Ensure your hand is dry when turning the power switch on/off and when inserting/removing the power cord from the receptacle.

12. If you are in any doubt about the electrical installation or safety of this product you must consult a qualified electrician.

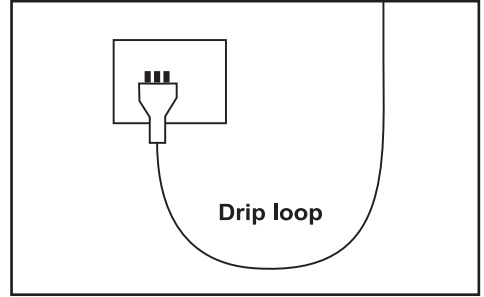

For Guarantee Conditions, please refer to the Guarantee form that is enclosed with this product.



Warning:

This appliance must not be disposed of together with domestic waste. It must be disposed of at an authorised centre set up for the recycling of electrical and electronic appliances. By collecting and recycling waste, you help save our natural resources. Please Make sure this product is disposed of in an environmentally friendly and safe way.

Before First Use / Preparation

Read and follow all the instructions, even if you feel you are familiar with the product and find a place to keep the instructions handy for future reference. Your attention is drawn particularly to the sections concerning "IMPORTANT SAFEGUARDS" and the "REPTILE ONE GUARANTEE". Please ensure you retain your original purchase receipt in the event that guarantee service is required.

Carefully unpack the water pump making sure you keep all the packing material until all the parts of the product have been found and the product has been assembled.

This product is shipped to you in a factory sealed carton. Should the product malfunction in any way or if the unit is damaged and requires replacement, contact the retailer where the product was purchased for inspection.

Know Your Water Pump 230

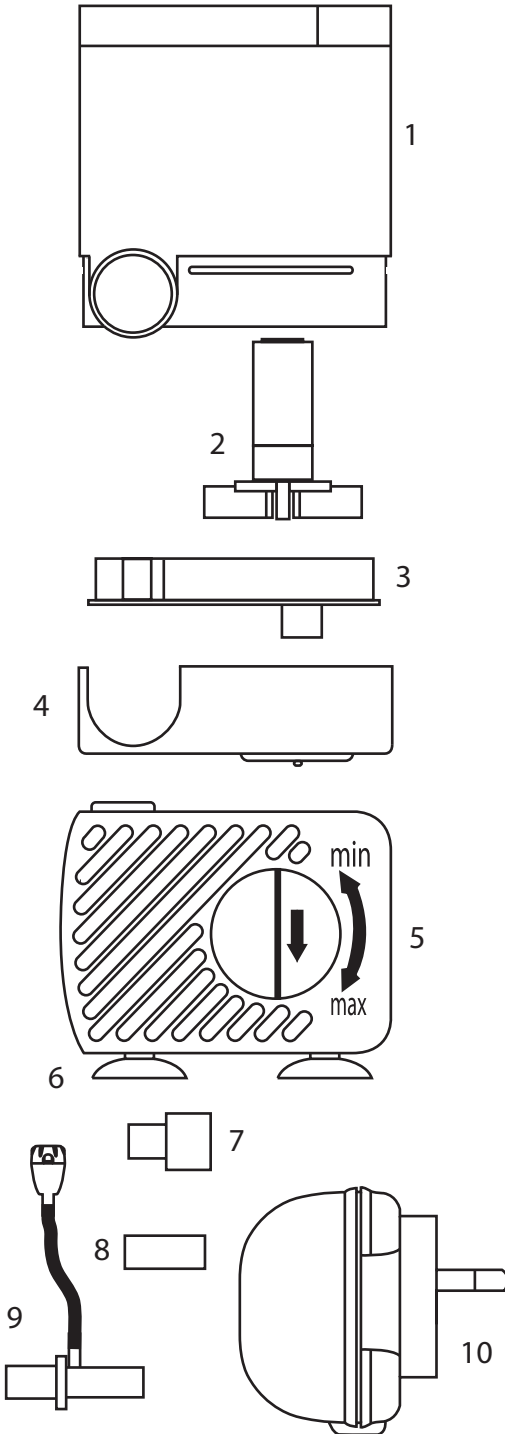

1. Motor
2. Impeller
3. Impeller cover
4. Pre filter
5. Flow controller
6. Suction cups
7. 13mm outlet
8. 9mm outlet
9. Venturi outlet with venturi & air line
10. Transformer

Pump Model: 230

Dimensions: 13 x 4 x 3cm

Maximum Flow Rate: 250L/hr

Maximum Head Height: 0.50m

Outlet Size: 9 + 13mm

Power Consumption: 3.5W

Power Requirements: 220 ~ 240V

Suitable: Reptiles, Amphibians

Replacement Parts & Filter Media

Use Reptile One Genuine Spare Parts Only. See your local Reptile One Dealer and look for the number listed below for the spare part you require. Alternatively you will find these numbers on the silver label located on the product.

230 Water Pump Impeller

616I

410 Water Pump Impeller

617I

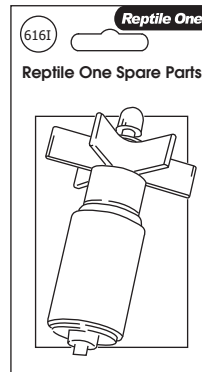

Installation 230

Reptile One mini water pumps are low voltage, the transformer is located on the plug. They come fully assembled and ready to use.

1. Decide on which outlet option to use.

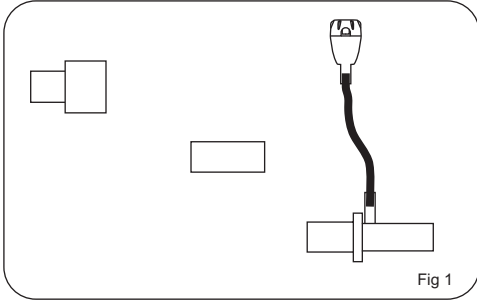

- a) If no attachment is required simply install the water pump as is, or push one of the other outlets into the water pump.

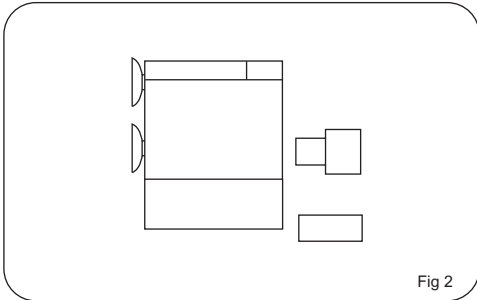

- b) If the venturi is required, push venturi outlet directly into pump outlet and hang the airline outside the terrarium.

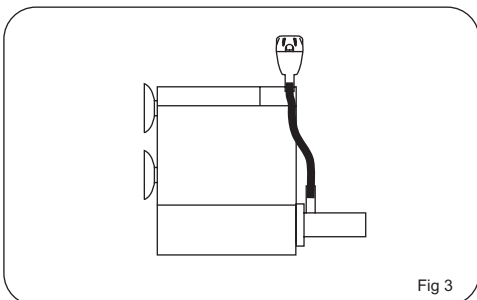

2. Suction cups will fasten the filter to the wall of your terrarium.

3. Use flow adjuster on the bottom of the power head:

max: will allow full flow

min: will reduce the flow

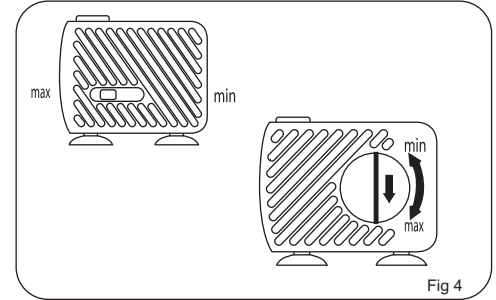

Maintenance 230

Clean the impeller at least once a month. Refer to the "Know Your Filter" page for help with the following procedure.

1. Remove the water pump from the terrarium and take it to the sink.

2. Grasp the motor with one hand and pre filter with the other and gently pull apart.

3. Remove the impeller cover to gain access to the impeller.

4. Pull impeller from the motor and rinse properly. Use an *Aqua One* double ended pipe brush (sold separately) to clean the impeller and the impeller chamber and also any of the outlet options that are being used.

5. Put the water pump back together and return to the terrarium. Ensure your hand is not wet, plug in at the power supply and turn "on".

Installation 410

Reptile One mini water pumps are low voltage, the transformer is located on the plug. They come fully assembled and ready to use.

1. Decide on which outlet option to use.

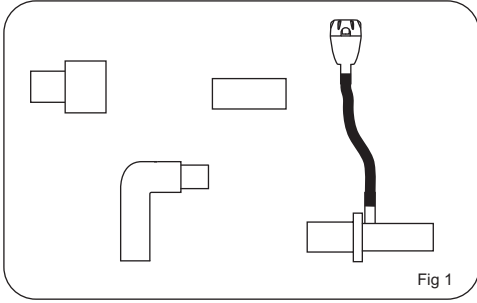

- a) If no attachment is required simply install the water pump as is, or push one of the other outlets into the water pump.

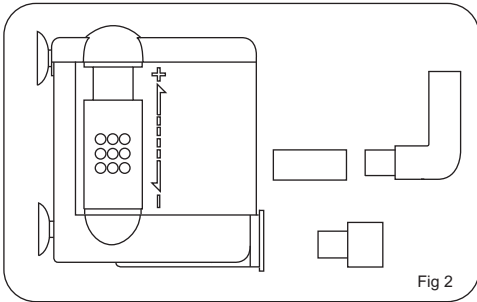

- b) If the venturi is required, push venturi outlet directly into pump outlet and hang the airline outside the terrarium.

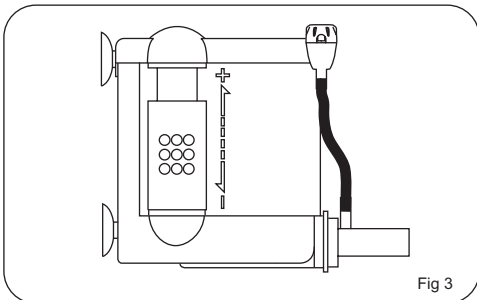

2. Suction cups will fasten the pump to the wall of your terrarium. It is best to have surface agitation.

3. Use flow adjuster on the bottom of the water pump:

- + will allow full flow
- will reduce the flow

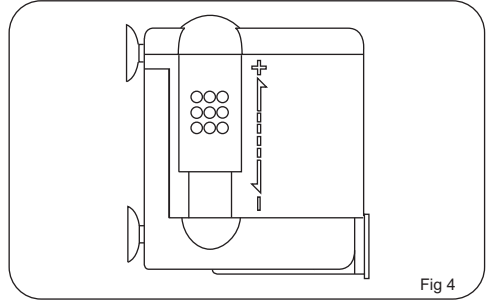

Maintenance 410

Clean the impeller at least once a month. Refer to the "Know Your Water Pump" page for help with the following procedure.

1. Remove the water pump from the terrarium and take it to the sink.

2. Grasp the motor with one hand and pre filter/mounting bracket with the other and gently pull apart.

3. Remove the impeller cover to gain access to the impeller.

4. Pull impeller from the motor and rinse properly. Use an *Aqua One* double ended pipe brush (sold separately) to clean the impeller and the impeller chamber and also any of the outlet options that are being used.

5. Put the water pump back together and return to the terrarium. Ensure your hand is not wet, plug in at the power supply and turn "on".

Reptile One - Guarantee 2 + 1 Year

The additional 1 Year Extended Guarantee applies when you REGISTER with Reptile One. See enclosed for details.

ATTENTION!

PLEASE RETAIN YOUR PROOF OF PURCHASE AND GUARANTEE

Congratulations on your purchase of a quality Reptile One product. This product will last you many years under normal usage.

About this Guarantee

The Manufacturer or Distributor, of Reptile One goods, is collectively known herein as "Reptile One". Please refer to contact details for Reptile One below or on the applicable Reptile One website. Any product that is covered by its own Guarantee (as enclosed with the product) is subject to the conditions of that Guarantee.

The benefits given to the purchaser, under Guarantee, are in addition to all other statutory rights and remedies which the purchaser has in respect of goods under legislation in the applicable country of purchase. This Guarantee shall not affect any such rights and should be read subject to such legislation.

1.0. Terms and Conditions of Guarantee.

- 1.1. Reptile One warrants to the purchaser, for 2 Years from date of original purchase, to repair or replace goods where fault is found due to defective materials or faulty workmanship and where goods do not operate in accordance with the instructions.
- 1.2. All claims for repair or replacement must be made at place of purchase.
- 1.3. The original and dated Proof of Purchase (receipt) must be supplied with all goods claims. Please also provide this Guarantee where possible.
- 1.4. All goods subject to claim under Guarantee should be prepared for transportation in the original packaging or other comparable packaging which offers the same degree of protection.
- 1.5. Where goods are repaired or replaced under Guarantee, these goods are Guaranteed for the remainder of either the original Guarantee or Extended Guarantee period.
- 1.6. Where claims on inspection reveal goods are in normal working order, Reptile One will request reimbursement of all reasonable costs incurred.

2.0. Other Terms and Conditions – Extended Guarantee

- 2.1. The Extended Guarantee period is for an additional 1 Year and commences on expiration of the standard guarantee period.
- 2.2. Application for Extended Guarantee is FREE of any registration cost to the purchaser on completion of the Extended Guarantee questionnaire which may be found with the Reptile One goods purchased or on the applicable Reptile One website. (See below)
- 2.3. Upon receipt and acceptance of the questionnaire, Reptile One will forward a Certificate of Extended Guarantee to the purchaser.
- 2.4. For more information on how we collect, hold, use and disclose personal information provided to us, please refer to our Privacy Statement on the Reptile One websites or write to our Privacy Officer, in your country of purchase*.
- 2.5. Where Reptile One determines goods are being used in a manner contrary to the instructions, specifications or this Guarantee, Reptile One reserves the right to terminate Extended Guarantee for such goods and will provide written notice to the purchaser.

3.0. Exclusions and Limitations

Where permitted by local law, the following exclusions and limitations apply in regard to the Guarantee:

- 3.1. Goods claims where fault is due to, but not limited by a) misuse b) neglect c) abuse d) fire or flood e) normal wear and tear f) accidental breakage g) Acts of God h) mains voltage fluctuation or supply problems i) connection to any voltage other than what is stated on the rating plate j) modification or tampering to electrical cord or plug, k) vermin, insects or foreign object l) liquid spillage or submersion of goods where goods are not designed to sustain such use or duress.
 - 3.2. Where inspections reveal goods are in normal working order including where noise or vibration is consistent with normal goods operation.
 - 3.3. Attempted repairs or modifications by unauthorised persons, including but not limited to modifications to the electrical lead or plug.
 - 3.4. Where the goods factory rating plate has been removed, altered, damaged or is rendered illegible.
 - 3.5. Where goods are not installed, operated or maintained in accordance with Reptile One's goods instructions, specifications or this Guarantee.
 - 3.6. Replacement or repair of worn consumables⁽¹⁾ or replacement of lost goods, parts or components.
 - 3.7. Costs associated with goods transportation, removal, installation, postage or cost of insurance.
 - 3.8. Any damage incurred whilst installing, transporting or moving the goods.
 - 3.9. Subject to certain local statutory rights and obligations to the contrary, and this guarantee shall not affect those rights or obligations, where, to the full extent permitted by law:
 1. all express and implied warranties and conditions under statute or general law, are expressly excluded and Reptile One, where permitted, will limit liability as follows and at Reptile One's option to: in regard to goods either a) the replacement of goods or supply of equivalent goods b) the repair of goods or the cost of replacing the goods or of acquiring equivalent goods OR in regard to services either c) the re-supply of services d) the cost to re-supply services.
 2. Reptile One will not be liable for any loss or damage, including consequential loss or damage either directly or indirectly, or for any incidental expenses, of any kind, and in any way whatsoever.
- (1) Consumables include items such as impellers, shafts and other plastic components.

*Precision Manufactured in the P.R.C.
Designed in Australia by Reptile One
Distributed in Australia by:
Kong's (Aust.) Pty. Limited
48 Williamson Rd. Ingleburn
2565 NSW Australia
www.reptileone.com.au

Distributed in New Zealand by:
Kong's (NZ) Limited
52 Glenlyon Avenue, Greerton
Tauranga New Zealand
www.reptileone.co.nz

Distributed in Hong Kong by:
Kong's Aquarium Supplies Co., Ltd
No 31, 3/F Thriving Industrial Centre
26-38 Sha Tsui Road, Tsuen Wan,
Hong Kong
www.reptileone.co.hk

Distributed in the UK by:
Kong's (UK) Limited,
C/O Aqua Pacific UK Ltd.
PO Box 268
Romsey Hampshire
SO51 0VWV
United Kingdom
www.reptileone.co.uk



Reptile One

www.reptileone.com.au

© Reptile One and Kong's are registered trademarks.



220 - 240V ~ 50HZ



Keep an eye out for these Reptile One products at your local retailer...



Reptile keeping has never been easier...

Reptile One specialises in all of your reptile and amphibian needs.

Reptile One uses state of the art technology which results in the most efficient and superior terrarium and vivarium products.

The Reptile One range includes a wide range of terrariums, vivariums, filters, water heaters, reflectors, heating equipment, lighting along with foods, cleaning and maintenance accessories and decorations.